

MAIN CHORDS Ø2.0 x 0.125				<u>SIZES</u>	MAIN CHORDS Ø1.9 x 0.145			
WEIGHT	ITEMS		REFERENCES	Length	ITEMS		REFERENCES	WEIGHT
Lbs (kg)								Lbs (kg)
33 (15)	TIP-	1212	-048 F.2_125	<- 48" ->	TIP-	1212	-048 F.9_145	33 (15)
40 (18)	TIP-	1212	-060 F.2_125	<- 60" ->	TIP-	1212	-060 F.9_145	40 (18)
55 (25)	TIP-	1212	-096 F.2_125	<- 96" ->	TIP-	1212	-096 F.9_145	55 (25)
63 (29)	TIP-	1212	-120 F.2_125	<- 120" ->	TIP-	1212	-120 F.9_145	63 (29)

Other sizes also available in 24" / 36" / 72" / 84"

Material: Truss: 6061-T6 / Spigots: 6061-T6 / Pin: Stressproof 1144

ALL OUR TRUSSES ARE MANUFACTURED BY CERTIFIED WELDERS

Tel : 514-400-3336

[info@therioinnovation.com](mailto:info@therioinnovation.com)



**ALLOWABLE LOAD TABLE :**

Span length	Uniformly Distributed Load				Center point				Third point				Quarter point			
	Load Capacity		Deflection		Load Capacity		Deflection		Load Capacity		Deflection		Load Capacity		Deflection	
ft (m)	lb/ft (kg/m)	lb (kg)	in (mm)	lb (kg)	in (mm)	lb (kg)	in (mm)	lb (kg)	in (mm)	lb (kg)	in (mm)	lb (kg)	in (mm)	lb (kg)	in (mm)	
8 (2.44)	864 (1286)	6911 (3135)	0.10 (2.6)	4030 (1828)	0.10 (2.4)	3023 (1371)	0.12 (3.1)	2015 (914)	0.11 (2.9)							
10 (3.05)	562 (836)	5617 (2548)	0.16 (4.2)	3212 (1457)	0.15 (3.8)	2409 (1093)	0.19 (4.9)	1606 (728)	0.18 (4.5)							
16 (4.88)	247 (367)	3948 (1791)	0.48 (12.2)	1974 (895)	0.39 (9.8)	1481 (672)	0.49 (12.4)	987 (448)	0.46 (11.6)							
20 (6.1)	155 (231)	3110 (1410)	0.75 (19)	1555 (705)	0.60 (15.4)	1166 (529)	0.76 (19.4)	777 (353)	0.71 (18.1)							
24 (7.32)	106 (158)	2541 (1153)	1.08 (27.4)	1271 (576)	0.87 (22.2)	953 (432)	1.10 (27.9)	635 (288)	1.03 (26.1)							
30 (9.14)	65 (97)	1959 (889)	1.68 (42.7)	980 (444)	1.38 (35)	735 (333)	1.72 (43.6)	490 (222)	1.61 (40.8)							
32 (9.75)	57 (84)	1810 (821)	1.91 (48.6)	905 (411)	1.57 (39.9)	679 (308)	1.95 (49.6)	453 (205)	1.83 (46.5)							
40 (12.19)	34 (50)	1350 (612)	2.99 (76)	675 (306)	2.49 (63.3)	506 (230)	3.05 (77.4)	338 (153)	2.87 (72.8)							
<i>Load per applied point</i>																

**NOTES :**

- Capacities shown in this table are valid for structures manufactured after January 2020.
- Trusses must be loaded uniformly on both sides of their longitudinal axis.
- Loads must be applied to or as close as possible to the nodes of the trusses.
- Deflection of truss is theoretical and based solely on their rigidity.  
It therefore does not take into account of the possible movement between the truss sections due to the tolerance of the pins/bolts.
- Datas are valid for indoor use only.
- Trusses are hung from the top chord only.
- Data are valid only for static loads and span, with two support points (one at each end).  
If dynamic loads or more attachment points are needed, **contact Therio Innovation.**

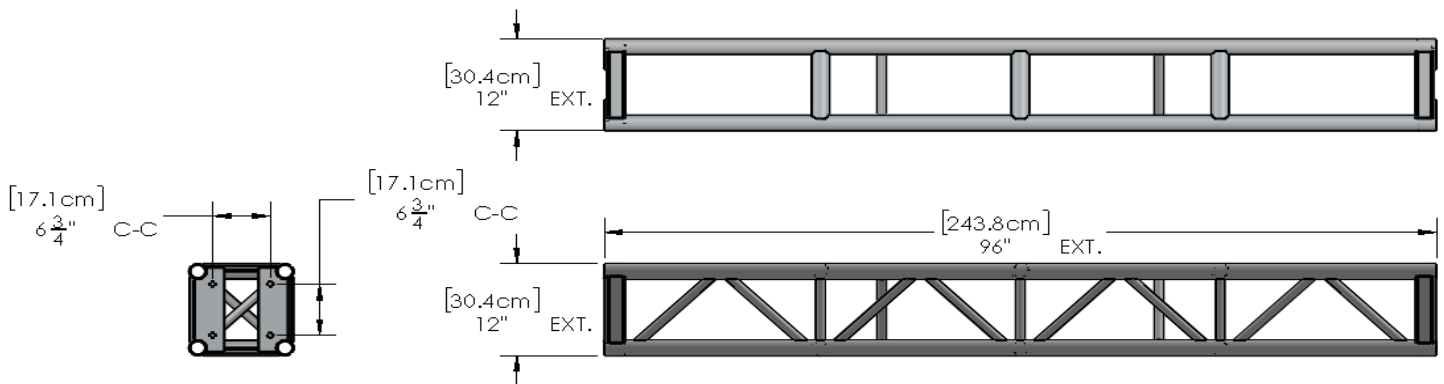
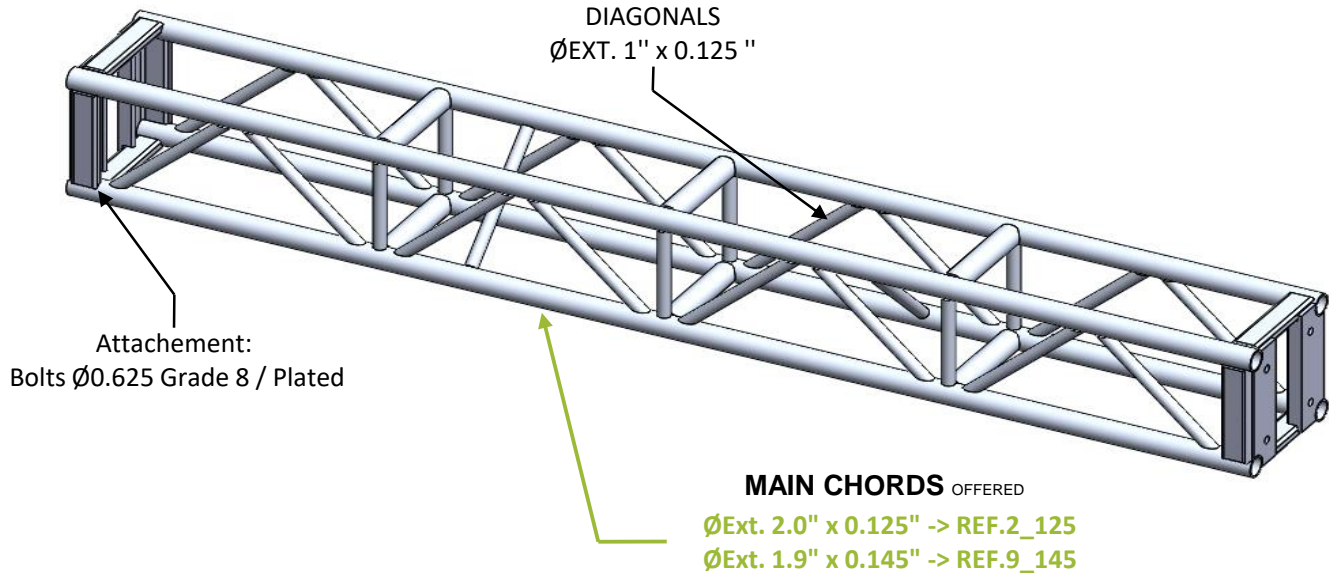

MAIN CHORDS Ø2.0 x 0.125				<b>SIZES</b>	MAIN CHORDS Ø1.9 x 0.145			
WEIGHT	ITEMS		REFERENCES	Length	ITEMS		REFERENCES	WEIGHT
Lbs (kg)								Lbs (kg)
31 (14)	TIP-	1212	-048 P.2_125	<- 48" ->	TIP-	1212	-048 P.9_145	31 (14)
38 (17)	TIP-	1212	-060 P.2_125	<- 60" ->	TIP-	1212	-060 P.9_145	38 (17)
54 (24)	TIP-	1212	-096 P.2_125	<- 96" ->	TIP-	1212	-096 P.9_145	54 (24)
65 (29)	TIP-	1212	-120 P.2_125	<- 120" ->	TIP-	1212	-120 P.9_145	65 (29)

Other sizes also available in 24" / 36" / 72" / 84"

Material: Truss & Plates: 6061-T6 / Bolts : Ø0.625 Grade 8

ALL OUR TRUSSES ARE MANUFACTURED BY CERTIFIED WELDERS

Tel : 514-400-3336

[info@therioinnovation.com](mailto:info@therioinnovation.com)

**ALLOWABLE LOAD TABLE :**

Span length	Uniformly Distributed Load				Center point				Third point				Quarter point			
	Load Capacity		Deflection		Load Capacity		Deflection		Load Capacity		Deflection		Load Capacity		Deflection	
ft (m)	lb/ft (kg/m)	lb (kg)	in (mm)	lb (kg)	in (mm)	lb (kg)	in (mm)	lb (kg)	in (mm)	lb (kg)	in (mm)	lb (kg)	in (mm)	lb (kg)	in (mm)	
8 (2.44)	430 (640)	3443 (1562)	0.05 (1.2)	3465 (1572)	0.08 (1.9)	1735 (787)	0.07 (1.7)	1157 (525)	0.06 (1.5)							
10 (3.05)	339 (504)	3386 (1536)	0.09 (2.3)	3412 (1548)	0.15 (3.7)	1711 (776)	0.13 (3.2)	1141 (517)	0.12 (3)							
16 (4.88)	207 (309)	3318 (1505)	0.37 (9.5)	2101 (953)	0.38 (9.6)	1576 (715)	0.48 (12.2)	1051 (477)	0.45 (11.3)							
20 (6.1)	162 (242)	3248 (1473)	0.72 (18.3)	1657 (751)	0.59 (15)	1242 (564)	0.75 (19)	828 (376)	0.70 (17.7)							
24 (7.32)	113 (168)	2712 (1230)	1.06 (26.8)	1356 (615)	0.86 (21.8)	1017 (461)	1.08 (27.4)	678 (308)	1.01 (25.5)							
30 (9.14)	70 (104)	2097 (951)	1.65 (41.9)	1048 (476)	1.35 (34.2)	786 (357)	1.68 (42.7)	524 (238)	1.57 (40)							
32 (9.75)	61 (90)	1940 (880)	1.88 (47.7)	970 (440)	1.54 (39.1)	727 (330)	1.91 (48.6)	485 (220)	1.79 (45.5)							
40 (12.19)	36 (54)	1455 (660)	2.93 (74.5)	728 (330)	2.44 (61.9)	546 (248)	2.99 (75.9)	364 (165)	2.81 (71.3)							
<i>Load per applied point</i>																

**NOTES :**

- Capacities shown in this table are valid for structures manufactured after January 2020.
- Trusses must be loaded uniformly on both sides of their longitudinal axis.
- Loads must be applied to or as close as possible to the nodes of the trusses.
- Deflection of truss is theoretical and based solely on their rigidity.  
It therefore does not take into account of the possible movement between the truss sections due to the tolerance of the pins/bolts.
- Datas are valid for indoor use only.
- Trusses are hung from the top chord only.
- Data are valid only for static loads and span, with two support points (one at each end).  
If dynamic loads or more attachment points are needed, **contact Therio Innovation.**